



# BP Schiehallion

# Case Study – BP Schiehallion



**Client:** BP North Sea      **Date:** 2009

**Project:** FPSO Schiehallion Recovery Project, UK

## Scope of work:

After an incident in which the FPSO Scheihallion was struck by the shuttle tanker 'Loch Rannoch', ACE Winches were asked by BP to supply a Winch Package to assist in the recovery of the Export Reel and Hose Assembly. The following package was supplied by ACE on a fast track basis in a remarkable 28 days.



The FPSO 'Schiehallion' and Shuttle Tanker 'Loch Rannoch'

 **ACE Winches**  
THE DECK MACHINERY SPECIALISTS

# Case Study – BP Schiehallion



## Project Details:

### 1 off 14 Tonne Double Drum Messenger Winch

As per BP's requirements the winch was certified to comply with current versions of the ATEX 94/9/EC Directive, Pressure Directive 97/23/EC and Machinery Directive 89/392/EEC including amendments.

- Rope Capacity: 200m of 40mm and 200m of 20mm Synthetic Fibre Rope
- Hagglunds Viking Hydraulic Motor

To support the 14 Tonne Double Drum Messenger Winch, ACE Winches also provided the following:

- 2 off ACE fully trained and qualified service and commissioning engineers to commission and supervise installation and start up of winch package on the FPSO Scheihallion.



# Case Study – BP Schiehallion



## Manufacturing Process – From Design to Completion in 28 days

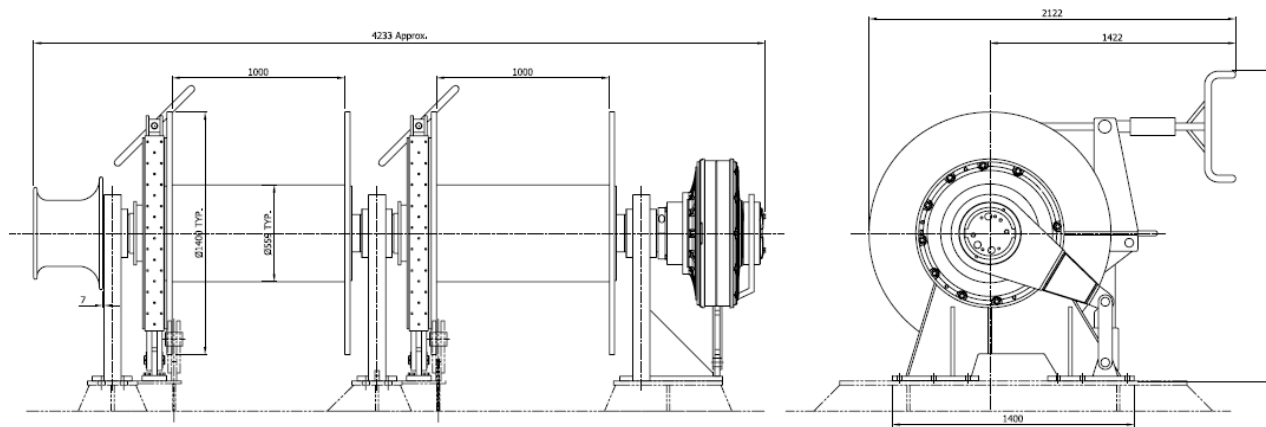

 **ACE Winches**  
THE DECK MACHINERY SPECIALISTS

# Case Study – BP Schiehallion



## Spooling and Testing at ACE's 750 tonne Spooling Bed



 **ACE Winches**  
THE DECK MACHINERY SPECIALISTS

# Case Study – BP Schiehallion



ACE Winches received a prestigious letter of thanks for their “pro-active effort and support” from the Managing Director of BP North Sea.



 **ACE Winches**  
THE DECK MACHINERY SPECIALISTS